

THM80X Series (THM801 / 802 / 803)

Industrial High Accuracy Temp. & Humidity Transmitter



| Features |

- IP65 , rugged aluminum case, fit in variety harsh environment
- Capable of temperature compensation. Linear adjustment temperature & humidity by computer, analog output or option RS-485
- Measure high accuracy Temp. & humidity, reaction quickly, the sensor can work well after temporary condensation, long term stable in high humidity environment
- Process Temp. : up to 200°C, S.S. probe proof pressure : 10 bar, metal connector : installation repeatedly
- Switch multifunction physical quantities : [%RH] 、 [°C] 、 [mbar] 、 [g/kg] 、 [g/m³] 、 [kJ/kg]
- Calibration physical quantities, measuring range, analog output, station, etc
- Free calibration software : data logger / record 65535 datas / charts

| Applications |

Semiconductor / Electronics / Industrial process monitoring / Air conditioning / Environmental ventilation control buildings / Factories / Hospitals / Clean rooms / Laboratories / Weather stations environmental monitoring / Storage rooms / Environmental chambers / Greenhouses / Mushroom farms / Paper / Printing Textiles / Steel and iron industry / Food / Chemical / Pharmaceutical / Biotechnology industry

| Specification |

Input

Signal type Capacitive humidity sensor & Pt 100 A class

Output

Output 0 ... 20 mA / 4 ... 20 mA

 0 ... 1 V / 0 ... 5 V / 0 ... 10 V

Signal connection 3-wire

Modbus 2 analog / option RS-485 (Programmable)

Display type LCD Module with back light, double line character

Display range upon request, one decimal place

Height of character 5.55 mm

Accuracy (at +25 °C)

Temperature $\pm 0.15^{\circ}\text{C} \pm 0.002^{\circ}\text{C} \times t_{\text{actual}}$

Humidity (0 ... 90 %RH) Nonlinear error : $\pm 1.2\% \text{RH}$

 Hysteresis error : $\pm 0.8\% \text{RH}$

 Repeatability error : $\pm 0.4\% \text{RH}$

Humidity (90 ... 100 %RH) $\pm 2\% \text{RH}$

Thermal sensitivity

Temp. error 0.05%RH/°C

Load resistance Current output : Max. 500 Ω

 Voltage output : min. 10 K Ω

Output calibration(ZERO & SPAN) Software / Keyboard

Response time t90 (at 25 °C) <20 sec (S.S.Metal grid filter with mesh)

 <30 sec (Sintered filter)

Factory uncertainty (at +25 °C)

Temp. uncertainty 0.14°C

Humidity uncertainty 0.4%RH (> 10 ... 20%)

 0.65%RH (> 20 ... 90%)

 0.97%RH (> 90 ... 98%)

Electrical

Power supply DC 8 ... 35 V / AC 12 ... 30 V

Current consumption DC 24 V : 60 mA / DC 12 V : 120 mA

 AC 24 V : 140 mA / AC 12 V : 230 mA

Electrical connection M12 metal connector with 2 m cable or

 terminal (Metal cable gland)

Environmental

Medium Air

Temp. Operating Housing : -20 ... +80°C

 Housing with display : -20 ... +60°C

Humid. Operating Housing : 0 ... 95% (Non-condensing)

Probe operating Wall type : -40 ... +80°C

 Duct type : -40 ... +120°C

 Remote type : -40 ... +200°C

Storage temperature -25 ... +60°C

Probe pressure resistance 10 bar

Certification

Certification CE

Protection

IP rating Housing : IP65 ; Probe : IP20

Electrical protection ■ Polarity protection

 ■ Over-voltage

 ■ Short-circuit

Installation

Installation Metal fitting thread

Material

Housing Aluminum alloy

Probe SUS 304

Cable Teflon

Weight THM801 : 455 g

 THM802 : 521 g

 THM803 : 635 g

*Please make sure the product and the device which connect with RS-485 are on common ground, avoid damaged product.

| Measuring Range List |

Beside temp. & dew point, other physical quantities range as default setting

Physical quantity	THM801 Wall type	THM802 Duct type	THM803 Remote type
Temperature(T)	-40°C ... +80°C	-40°C ... +120°C	-40°C ... +200°C
Humidity(H)	0 ... 100%RH		
Dew point(D)	-40 dp°C ... +60 dp°C		
Frost point(F)	-40 ... 0 fp°C		
Wet-bulb Temp.(W)	0 ... 100°C		
Vapor pressure(E)	0 ... 1100 mbar		
Mixture ratio(R)	0 ... 999 g/kg		
Absolute humidity(A)	0 ... 700 g/m ³		
Specific enthalpy(S)	0 ... 2800 kJ/kg		

| Temp. & Humidity QC Inspection System |

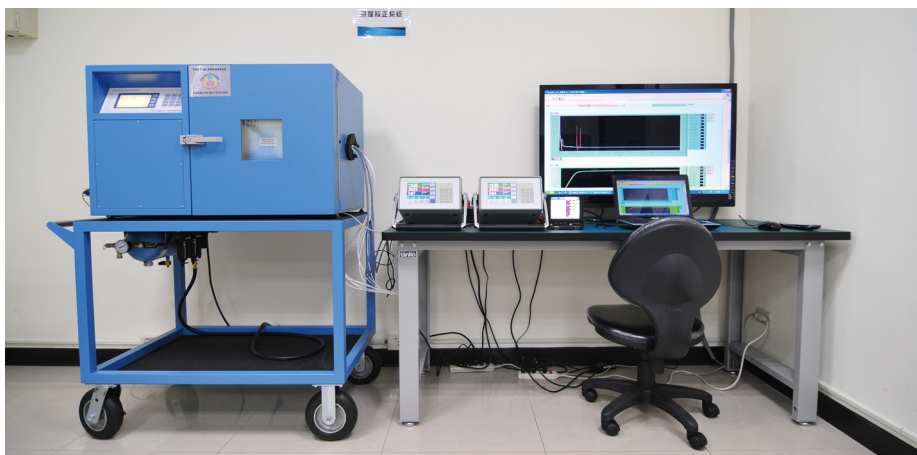

- System Facility
- Humidity generator
- Dew point mirror
- Laboratory level facility to produce products, and automatic QC inspection sheet printing and factory report

| 3-cycle curve |

※ According to IEC 61298 and ISO 17025 standard to measuring 3-cycle curve.

As the charts result, accuracy of test sample match with accuracy chart of humidity generator + dew point mirror

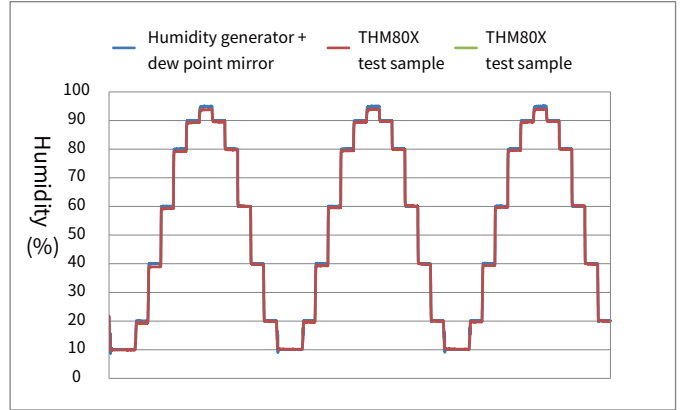
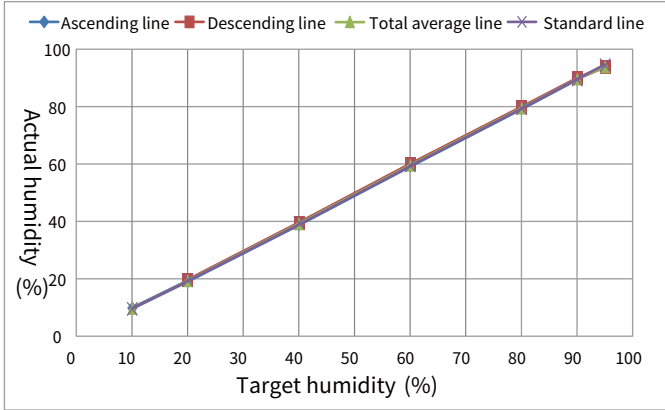

| Electric Connector | Unit : mm

【M type (M12-4PIN metal connector) RS-485 or analog】

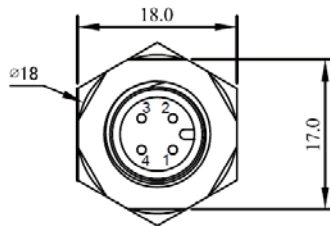
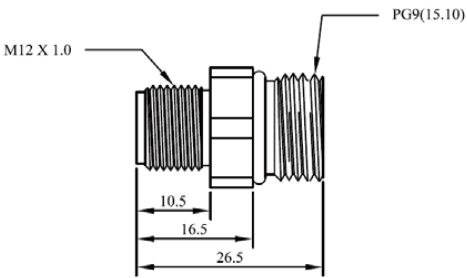

【M type (M12-8PIN metal connector) RS-485+analog】

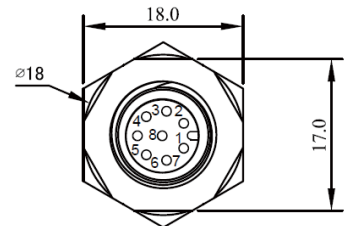

【N type (M16 cable gland) RS-485+analog】

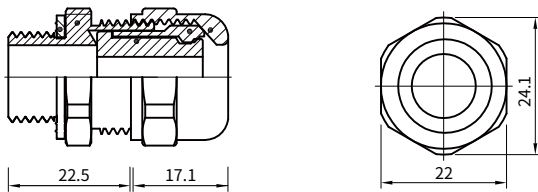

| Analog Diagram |

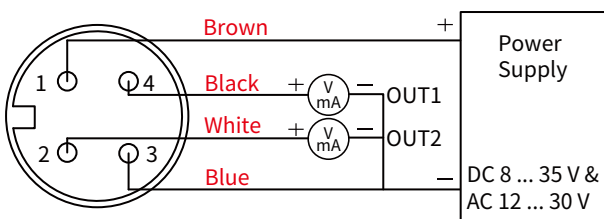

M12 connector

M type (4P)

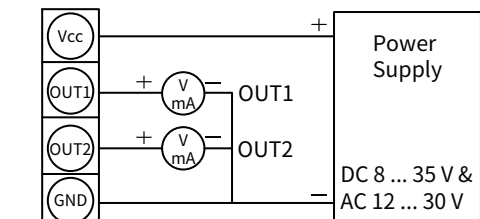

4P terminal

N type

| RS-485 Diagram |

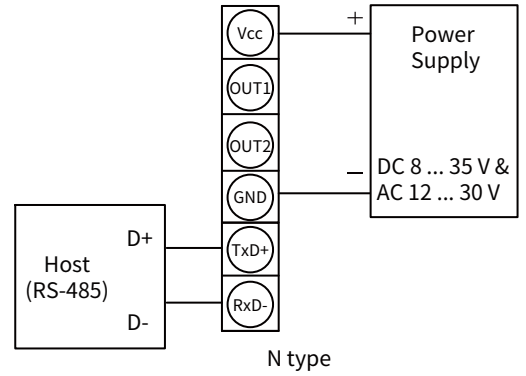
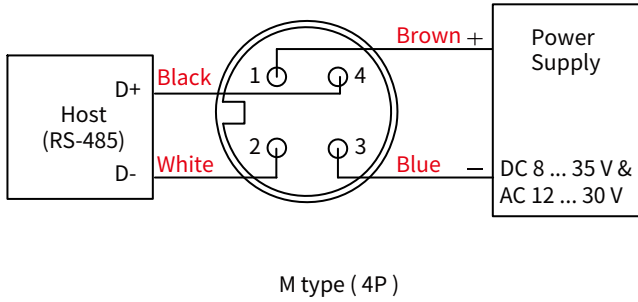

※ When output of ordering code is RS-485 (without analog), RS-485 diagram of default setting is M type.

| Analog+RS-485 Diagram |

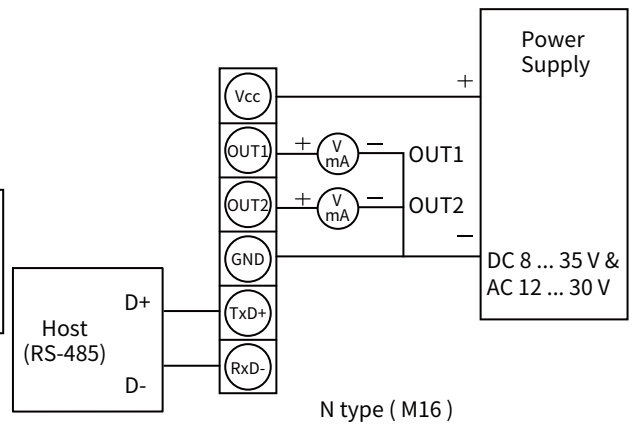
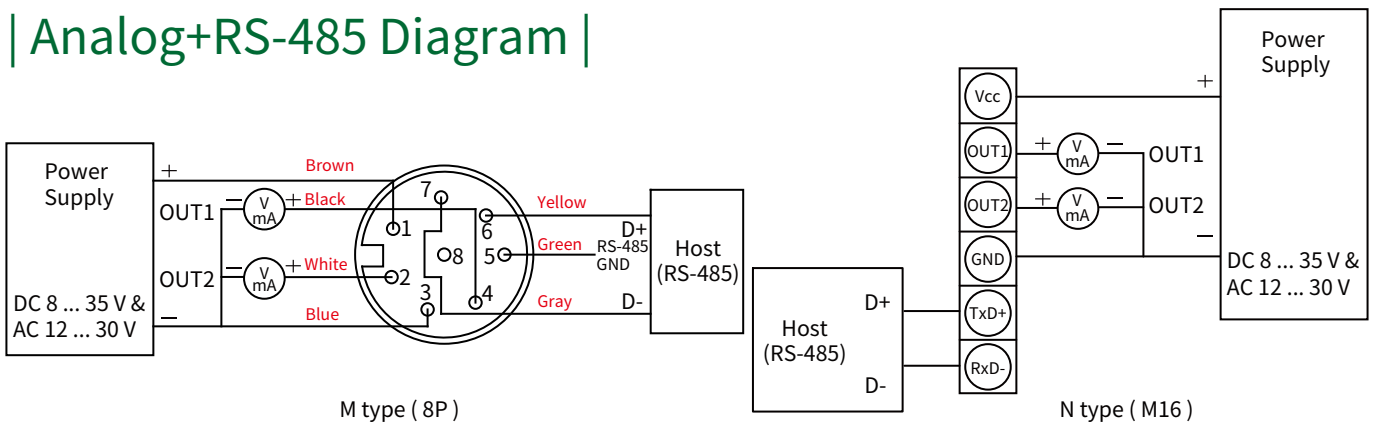

| Dimension |

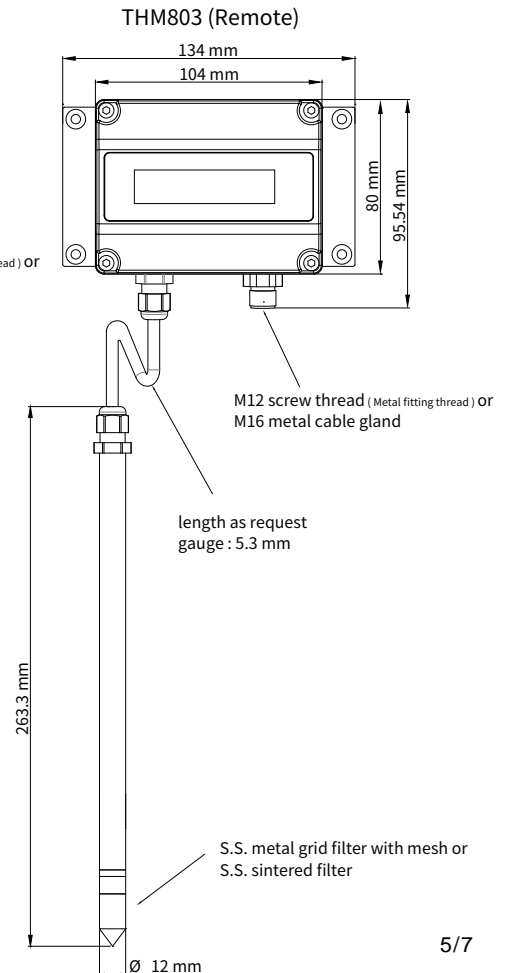
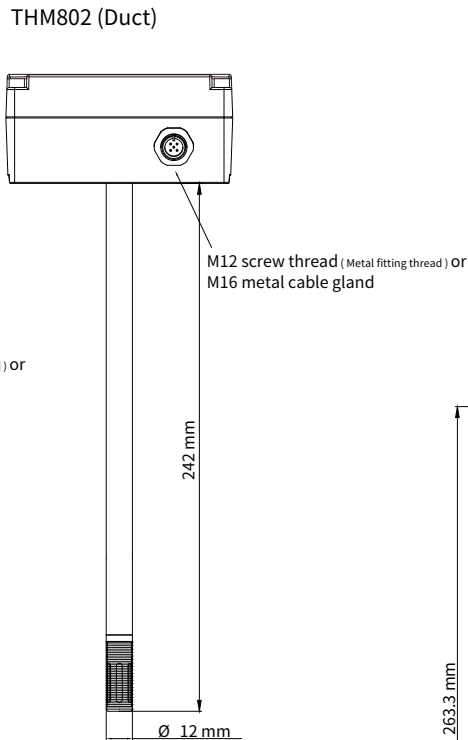
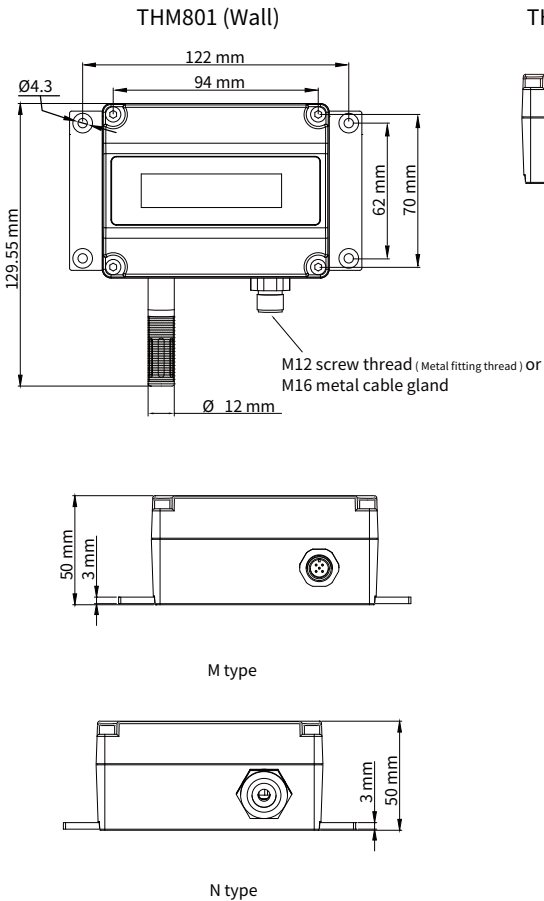

| Ordering Guide |

THM80 **3** — **T** **48** **1** **H** **00** **1** — **D** **N** **S** **2** **U**

<p>Installation</p> <p>1 : Wall 2 : Duct 3 : Remote</p>	<p>Physical quantity output 1</p> <p>T : Temperature H : Humidity D : Dew point F : Frost-point W : Web-bulb temperature E : Vapor pressure R : Mixture ratio A : Absolute humidity S : Specific enthalpy N : RS-485 (Default Temp.)</p>	<p>Physical quantity scale 1</p> <p>48 : 0 ... +120°C 42 : 0 ... +120°C 47 : 0 ... +200°C 13 : -20 ... +40°C 14 : -40 ... +60°C 16 : -40 ... +120°C 18 : -40 ... +180°C 20 : -40 ... +200°C 49 : -70 ... +180°C 00 : As physical quantity measuring range list YY : Customized (up to 200°C)</p>	<p>Signal output 1</p> <p>1 : 4 ... 20 mA 2 : 0 ... 20 mA 6 : 0 ... 10 V 7 : 0 ... 5 V 8 : 0 ... 1 V 9 : RS-485</p>	<p>Physical quantity output 2</p> <p>H : Humidity D : Dew point F : Frost-point W : Web-bulb temperature E : Vapor pressure R : Mixture ratio A : Absolute humidity S : Specific enthalpy N : RS-485 (Default Temp.)</p>	<p>Physical quantity output 2</p> <p>00 : As physical quantity measuring range list YY : Customized (up to 200°C)</p>	<p>Signal output 2</p> <p>1 : 4 ... 20 mA 2 : 0 ... 20 mA 6 : 0 ... 10 V 7 : 0 ... 5 V 8 : 0 ... 1 V 9 : RS-485</p>	<p>Display</p> <p>X : No D : Yes</p>	<p>Electrical connector</p> <p>N : M16 metal cable gland M : M12 metal connetor</p>	<p>Filter</p> <p>S : Sintered filter</p>	<p>Remote Cable Length (TEFLON)</p> <p>2 : 2 m 5 : 5 m — : Customized (Max. length : 10 m)</p>	<p>Other request</p> <p>W : Other request (Quote as demand) U : RS-485 + analog</p>
---	--	--	---	--	---	---	--	---	--	--	---

| Additional Option Test Report |

For more detailed information please contact us.

■ ILAC / TAF

Calibration Laboratory - (ILAC / TAF) Test report.

(TAF accreditation:3032, complying with ISO / IEC 17025) TAF has mutual recognition arrangement with ILAC MRA

Project	Measurand level or range
Hygrometer	Temperature : 0°C ... 69.5°C
	Humidity : 10% ... 95%

Project	Measurand level or range
Dew point transmitter	$\geq -80 \text{ dp}^\circ\text{C} \dots \leq 60 \text{ dp}^\circ\text{C}$

■ ISO 9001

Project	Measurand level or range
Temperature and Humidity	Temperature : 0°C ... 200°C
	Humidity : 0.1% ... 99.8%

Project	Measurand level or range
Dew point	$\geq -95 \text{ dp}^\circ\text{C} \dots \leq 60 \text{ dp}^\circ\text{C}$